

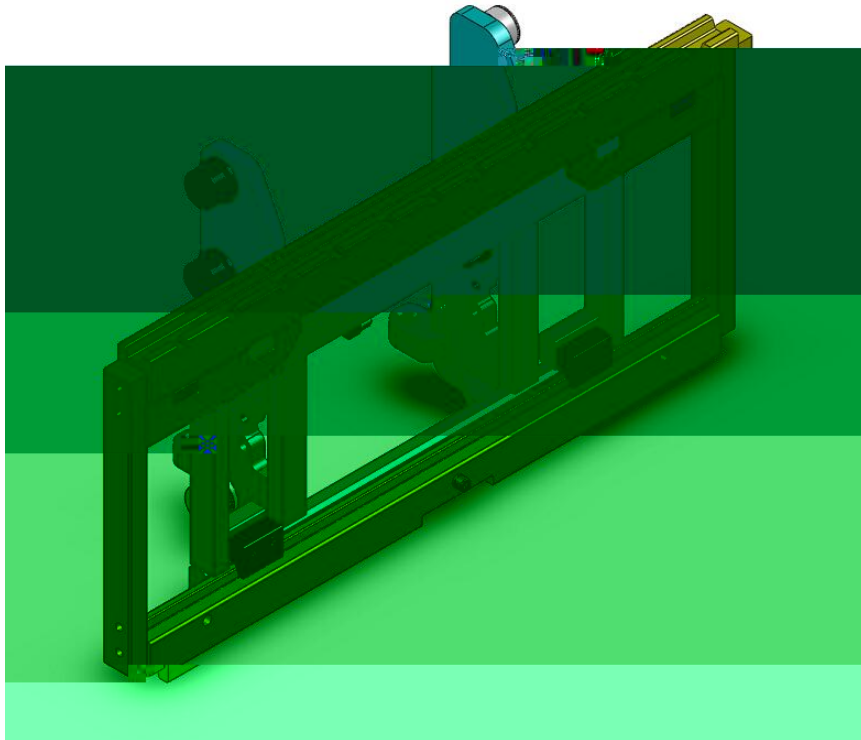

---









1-2mm

160Nm 170Nm

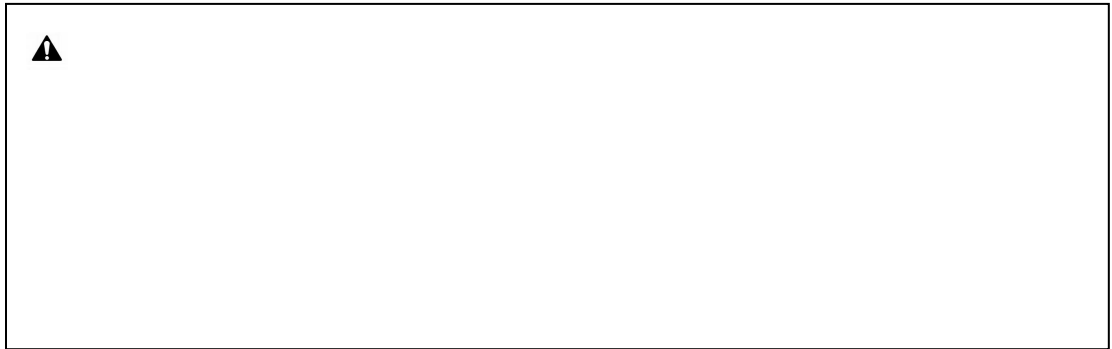





160bar